



MID SWEEP 01

Dual Range Mid Sweep Module

The MID SWEEP 01 is a stand-alone mid control which can be used on its own or cascaded in conjunction with other modules, including additional MID SWEEP 01s. The sweep frequency band is switchable, via DIL switches on the circuit board, between two overlapping ranges.

- **MID LEVEL & FREQUENCY**

- **BOOST/CUT (+/-12dB)**

The upper knob sets the amount of Mid boost or cut at frequencies according to the setting of the Frequency knob. The midway indent is the 'flat' setting.

- **FREQUENCY (100Hz - 1kHz or 200Hz - 2kHz)**

The lower outer ring sets the continuously variable Mid frequencies for boost or cut. DIL switches on the circuit board allow low or high ranges to be set. Both switch sections should be set to ON for the Low Range and both set to OFF for the High Range.

- **POWER**

This unit can be powered from 9 - 18 Volts DC.

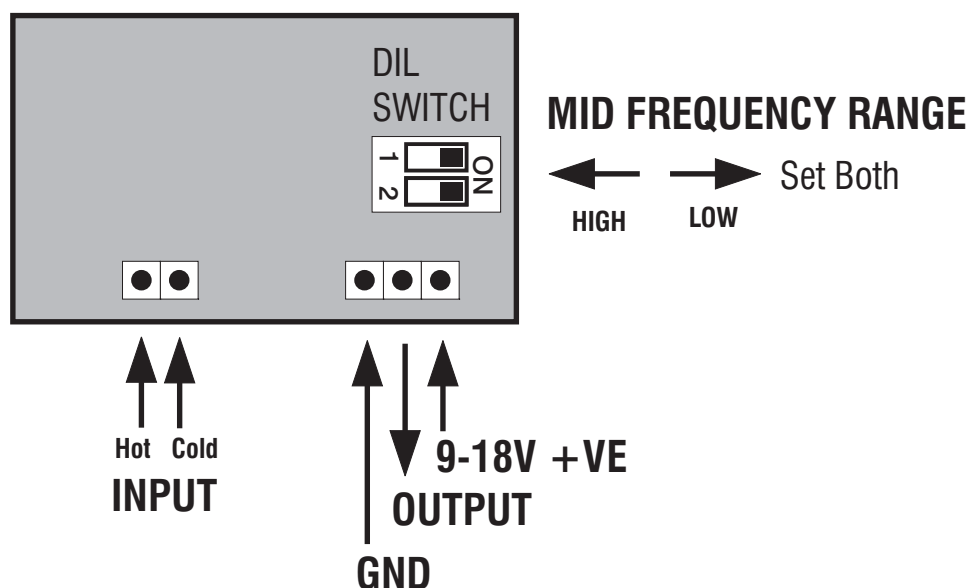



CARE & SAFETY

- This unit does not contain any user-servicable parts. Any repairs or maintenance should be carried out by qualified personnel only.
- Do not allow this unit to get wet or expose it to damp conditions.
- Do not leave a battery connected to the unit for extended periods if not in use.

GUARANTEE

Your East product is guaranteed to be free from defects in materials and workmanship for a period of one year from the date of original purchase.

If during the guarantee period your product becomes faulty due to defective materials or workmanship then the unit will be repaired or replaced without charge for parts or labour at the discretion of East UK according to the conditions below.

CONDITIONS

- 1 The original sales invoice or receipt indicating the date of purchase and sales outlet is presented together with the faulty unit.
- 2 The unit was installed competently consistent with the instructions supplied.
- 3 What is not covered:
 - a) Damage due to accident or improper handling, installation or operation.
 - b) Defects caused by the instrument or system to which to which the unit has been installed.
 - c) Damage resulting from repair of the unit carried out by non-authorized service personnel.
 - d) The costs of transport or shipping costs relating directly or indirectly to the guarantee of this product.